

MODEL: P6060B1B*

*ALL ACCESSORIES OPTIONAL

BARRIER FREE

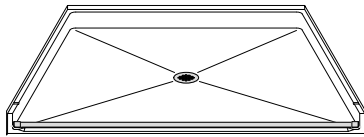

PERSPECTIVE VIEW - N.T.S.

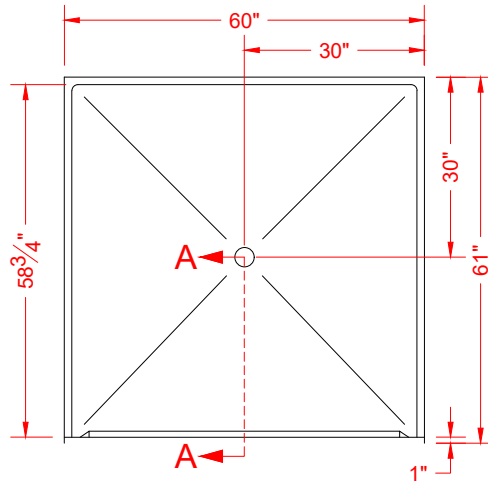

TOP VIEW - SCALE $\frac{3}{8}'' = 1'-0''$

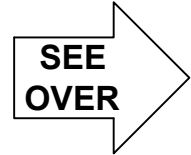

Features:

- Molded, one-piece gelcoat/fiberglass barrier free shower pan
- Available in various threshold heights
- On all threshold heights 1-1/4" or shorter, no mud set is required and an anchoring adhesive kit is supplied
- On all threshold heights 1-1/2" or taller, no mud set is required

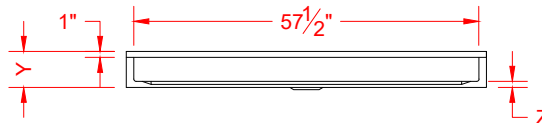

FRONT ELEVATION - SCALE: $\frac{3}{8}'' = 1'-0''$

* - SEE BACK FOR DETAIL SECTIONS

MODEL #	UNIT HEIGHT Y	THRESHOLD HEIGHT Z*
P6060B1B	6"	1" MIN.
P6060B2B	7"	2" MAX.

PRODUCT SPECIFICATIONS:

- Single-piece shower pan shall be constructed of gelcoat/fiberglass
- Rough-In: Stud opening +1/4" -0" Nominal Dimensions.

C.S.I. FORMAT SPECIFICATION TEXT AVAILABLE

PRODUCT INFORMATION:

- Colors: White as standard, others to match any major fixture manufacturer, also available with sprayable solid surface in many colors
- Custom curb heights, other than shown, are available (between min. and max.)

OPTIONAL ACCESSORIES:

INSTALLED BY OTHERS:

- T-Shaped rubber WaterStopper kit
- Semi-permanent threshold adaptor
- No-caulk brass drain

CODES:

- Designed and manufactured in compliance with the following standards and codes:
- ANSI Z124.2 Standards for Plastic Showers
 - ANSI A117.1 B - Accessible and Usable Buildings and Facilities
 - IPC International Plumbing Code
 - UPC Uniform Plumbing Code

NOTICE OF LIMITATION:

- Adhere to floor as required



We reserve the right to make revisions without notice in the design of fixtures or in packaging unless this right has specifically been waived at the time the order is accepted.

□ P6060B1B

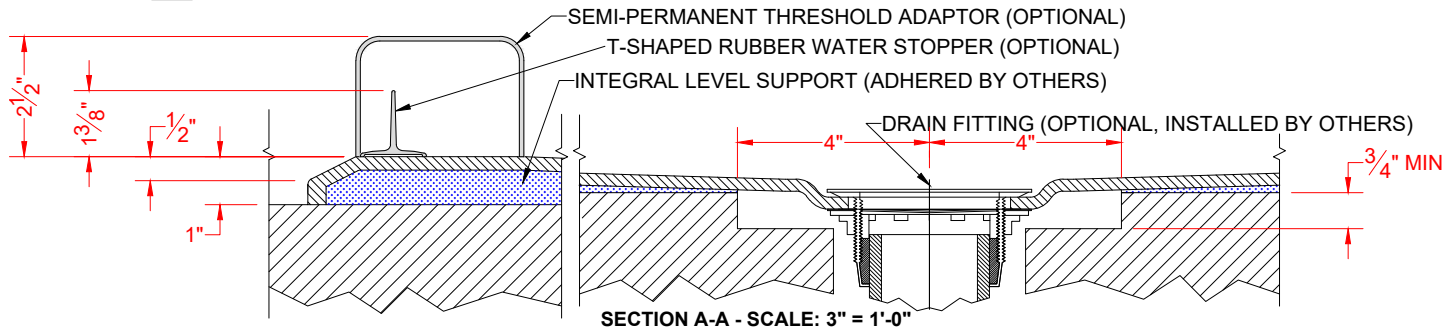

□ P6060B2B

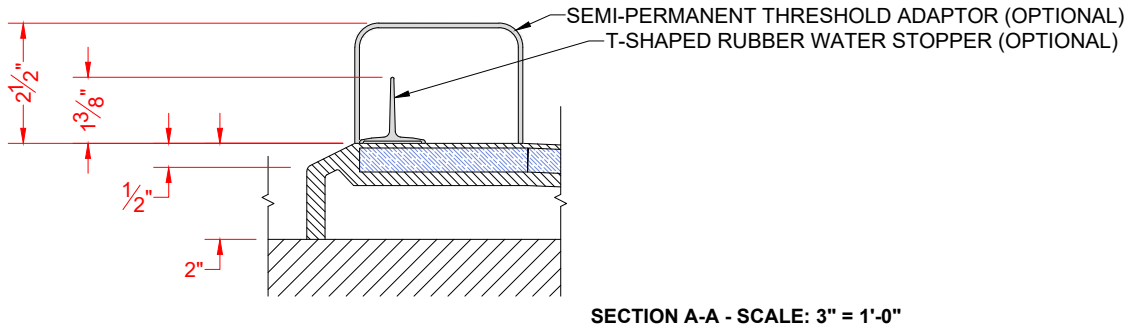

****OTHER THRESHOLD HEIGHTS AVAILABLE UPON REQUEST****